



OkuStim[®] 2 System

Instructions for use



EN

Quick guide to conducting a therapy session

Preparation of the stimulation

- 1 Thoroughly clean the skin on the left and right sides of the forehead with an alcohol swab.
- 2 Apply the two OkuEI counter electrodes to the cleaned areas of skin. Make sure that the entire surface of the counter electrode is adhered smoothly and completely. Reseal the package containing the unused OkuEI counter electrodes tightly and as airtight as possible.
- 3 Place OkuStim 2 upside down on a dry surface. The two brackets point away from you.
- 4 Insert the two OkuEI M electrodes into the electrode holders (magnetic holders) of OkuStim 2. Ensure that the orange seal faces outwards.
- 5 Moisten your eyes with eye drops.
- 6 Sit in a comfortable and stable position. Ideally, your head or entire upper body should be tilted slightly backwards.
- 7 Switch on OkuStim 2. To do this, press and hold the on/off button on the left bracket for at least two seconds.
- 8 Put on OkuStim 2.
- 9 Connect the two OkuEI counter electrodes to the cables on OkuStim 2.
- 10 Gently pull down the lower eyelid with one hand while keeping your eye open. Use the rotary handle on the side of OkuStim 2 to swing the electrode holder into position so that OkuEI M makes good contact with the eye.
- 11 Repeat step 10 for the other eye.
- 12 Close your eyes and keep your head still and slightly tilted back.
- 13 Start stimulation. To do this, press the start/pause button on the right-hand bracket of OkuStim 2.

After stimulation

- 1 Open your eyes and remove the two OkuEI M electrodes from your eyes using the two rotary handles on OkuStim 2.
- 2 Disconnect the two cables from the OkuEI counter electrodes by carefully pulling them off the snap connectors.
- 3 Remove OkuStim 2 from your head.
- 4 Switch off OkuStim 2. To do this, press the on/off button on the left bracket for at least 2 seconds. OkuStim 2 also switches off automatically five minutes after the end of the therapy session.
- 5 Remove the used OkuEI M from the electrode holders and dispose of them in the general waste.
- 6 Remove the OkuEI counter electrodes from the skin and dispose of them in the general waste.
- 7 Recharge OkuStim 2 for at least 2 hours using the power supply unit provided.

You will find detailed step-by-step instructions in chapter 5.

Important information

Copyright © 2025 Okuvision GmbH. All rights reserved.

No part of this publication may be reproduced, transmitted, transcribed, stored in a retrieval system, or translated into any language or computer language in any form or by any means, or by any third party, without the prior written permission of Okuvision GmbH.

All software described in this publication is provided under a licence agreement. All other trademarks are the property of their respective owners. Other company and brand products and service names are trademarks or registered trademarks of their respective owners.

Intended use

OkuStim is intended for the electrical stimulation of the eye of patients with retinitis pigmentosa in an outpatient or home setting.

Clinical benefits

Electrostimulation therapy with the OkuStim 2 system can help slow down the decline in visual field in patients with retinitis pigmentosa, thereby preserving useful vision for longer.

Users and environment

The OkuStim 2 system is suitable for electrical stimulation by trained lay persons and specialist users in clinics, practices or at home. The stimulation parameters must always be programmed by a healthcare professional.

Purpose of these instructions for use

These instructions for use contain the information necessary for the safe operation of the OkuStim 2 system in accordance with its function and intended purpose.

These instructions include:

- An explanation of how the controls, displays and acoustic signals work.
- Instructions for using the OkuStim 2 system
- Instructions for conducting stimulation sessions
- Notes on maintenance and troubleshooting

Version note

These instructions for use apply to OkuStim 2 devices with firmware version 1.0.1 or higher.

Manufacturer





Okuvision GmbH
Gerhard-Kindler-Str. 17
72770 Reutlingen | Germany
Tel. +49(0)7121 159 35-0
Email info@okuvision.de | www.okuvision.de

Symbol glossary

The following symbols can be found on the packaging and description of the OkuStim 2 system components:
OkuStim 2/OkuEI M/OkuEI counter electrode

 **MD** Medical device

 Follow the instructions for use

 Follow the instructions for use

 General warning sign

 **LOT** Batch number

 **SN** Serial number

 Use by

 Date of manufacture

 The CE mark certifies compliance with the Medical Devices Regulation (EU) 2017/745 MDR. Notified body: TÜV Rheinland (= 0197)

 Example of storage temperature

 Packaging unit

 Not for reuse

 Example of temperature range (Storage and application)

 Manufacturer

 **REF** Article number

 Do not use if packaging is damaged

 Follow disposal regulations

 Application part type BF

 **UDI** Unique product identification

Enclosure protection class:
IP22 Protected against solid foreign objects with a diameter of 12.5 mm or more and against dripping water at a 15° angle

 FCC compliant

Important safety information

- This product may only be used in accordance with medical instructions and after prior adjustment by healthcare professionals. Only use the device that is specifically intended for you.
- Before using the device, familiarise yourself with these operating instructions and observe the information on electromagnetic compatibility (Chapter 16).
- The OkuStim 2 system is a medical device for a rare disease.
- The OkuStim 2 system is available only on prescription.
- Stimulation is not possible while OkuStim 2 batteries are charging.
- No radio connection is possible while OkuStim 2 batteries are charging.
- The batteries of OkuStim 2 must not be charged while the device is being worn.
- Only use the accessories included in the scope of delivery or listed in Chapter 3 and Chapter 16. Do not connect any cables or parts that are not specified for use with the device.
- Only the supplied power supply unit and cable may be used for charging.
- Only the cable supplied may be used for data transfer to the PC.
- While the cable is connected between the PC and OkuStim 2, OkuStim 2 must not be worn. Stimulation is not possible.
- Do not use OkuStim 2 if it is hot in the area of the battery or if the device is damaged.
- The OkuEI M consists of a silver thread. Users with silver allergies may only use the OkuEI M after consulting a doctor.
- The use of local anaesthetics on the eye and the use of therapy while wearing contact lenses are not permitted.
- When using the OkuStim 2 system in conjunction with silicone oil tamponade of the eye, the functionality of the stimulation cannot be guaranteed.
- If you are using a hearing aid (approved CE-marked medical device) for medical purposes under typical conditions, you can continue to wear it while it is switched on during stimulation, provided it is not an implanted medical device (see contraindications on page 8).
 - For patient-specific questions, please contact the prescribing doctor or the manufacturer of the hearing aid.
 - If you feel uncomfortable during stimulation, switch off the hearing aid and do not wear it for the duration of the stimulation. In this case, please contact the manufacturer of the hearing aid.
- The device and its electronic accessories must not be opened or modified.
- The device must not be disassembled, crushed, heated to over 100 °C, short-circuited or burned. Due to the batteries, this may lead to an increased risk of fire, explosion or burns.
- During a stimulation session with OkuStim 2, no additional examinations or treatments, involving electrostimulation of the body, may be performed.
- Only use the device while sitting or lying down. Avoid moving around with it and keep it away from objects that could snag the electrode holders or counter electrode cables.
- Please note: The current flow density at the OkuEI M may exceed 2 mA/cm².

- Keep the device and its accessories out of the reach of children. Small parts such as the OkuEI M could be swallowed.
- Check the OkuEI M blister pack and the OkuEI counter electrode packaging. Only use them if the packaging is intact.
- The OkuEI M and OkuEI counter electrodes are disposable items and must not be reused. If an OkuEI M and/or OkuEI counter electrode is reprocessed and/or used for more than one treatment session, the safe functionality of the OkuEI M and/or OkuEI counter electrode cannot be guaranteed.
 - Repeated use may render the treatment ineffective and lead to eye infections.
- Only use the OkuEI M and the OkuEI counter electrode if they are in perfect condition. If you notice any anomalies, don't use the product.
- Do not use the device or its accessories if you have any skin injuries.
- Please note that two magnets are integrated into the OkuStim. Keep magnetic components (e.g. credit cards) and mechanically incompatible components well away from OkuStim 2.

Obligation to report

Please note that all serious incidents related to the product must be reported to the manufacturer and the competent authority of the Member State in which the user and/or patient is located.

[In accordance with Annex I, Chapter III of the EU Medical Devices Regulation (EU) 2017/745].

Indications and contraindications

Indications

Transcorneal electrical stimulation (TES) with the OkuStim 2 system is indicated for the treatment of:

- Retinitis pigmentosa (also syndromic, e.g. Usher syndrome)¹

Contraindications

- TES therapy must not be used in the following cases:
- In patients with vascular growth processes that could be accelerated by electrostimulation, such as:
 - Ocular neovascularisation of any origin
 - Macular oedema
 - Arterial or venous occlusions
 - Diabetic retinopathy
 - Age-related macular degeneration
- Patients who, according to medical assessment, have a severe acute or chronic illness (medical, psychiatric, other abnormal findings) that could worsen as a result of the therapy.
- For patients with active implants².
- During pregnancy.
- For breastfeeding mothers.
- For acute eye inflammation.

The prerequisites for the application of transcorneal electrostimulation therapy are:

- Minimum age: 18 years
- Visual acuity: at least light perception
- Patients must be able to sit still for 30 minutes.

¹ In the current S1 Guideline 25 (AWMF 045/23) for hereditary retinal, choroidal and optic nerve diseases issued by the German Ophthalmological Society (DOG), the Retinological Society (RG) and the Professional Association of Ophthalmologists in Germany (BVA), electrostimulation is mentioned as a recommended treatment (German Ophthalmological Society 2021).

² The OkuStim 2 system must not be used if you have an electrical implant that is classified as an application part within the meaning of standard EN 60601-1. Please contact the manufacturer of the implant.

This page has been intentionally left blank.

Contents

Quick guide to conducting a therapy session	2
Important information	4
Intended use	4
Clinical benefits.....	4
Users and environment	4
Purpose of these instructions for use	4
Version note.....	4
Manufacturer.....	4
Symbol glossary.....	5
Important safety information	6
Obligation to report	7
Indications and contraindications	8
Contents	10
1 What is the OkuStim 2 system?	12
1.1 Control knobs and setting options.....	14
1.2 OkuEI M	16
2 Therapy	16
3 Scope of delivery of the OkuStim 2 system.....	16
4 Information before first use	17
5 Step-by-step instructions: Stimulation by the patient themselves	18
6 Charging OkuStim 2	30
7 Disinfection and cleaning	30
8 Side effects.....	31
9 Light and sound signals	32
9.1 LED positions	33
9.2 Button functions and light and sound signals	34
9.3 For healthcare professionals: Additional button functions, light and sound signals.....	38
10 Storage.....	39
11 Repair and maintenance.....	40
12 Error handling	40
13 Technical data	49
13.1 Power supply.....	49
13.2 Connections	49
13.3 Memory card	49
13.4 Housing.....	49

13.5	Service life	49
13.6	Operating conditions	50
13.7	Storage and transportation conditions	50
13.8	Stimulation parameters	50
13.9	Key performance feature	50
13.10	Basic safety	50
14	Disposal of old devices	50
14.1	Disposal of electrical and electronic devices	50
14.2	Data protection	51
15	Warranty	51
16	Accessories	51
17	Notes on radio technology	51
18	Notes on electromagnetic compatibility	52
	Annex 1: For healthcare professionals and dealers only - Handling and application	55
A.1	Adjusting OkuStim 2	55
A.2	The OkuStim 2 nose bridge exchange or replacement	56
A.3	Patient workflow	57
A.4	Error handling	61

1 What is the OkuStim 2 system?

OkuStim 2 is a system for transcorneal electrical stimulation (TES) for the treatment of retinal dystrophies. The external therapy can be used independently at home.

Electrostimulation therapy with the OkuStim 2 system can slow down the narrowing of the visual field in retinitis pigmentosa (including syndromic forms such as Usher syndrome) and preserve useful vision for longer.

Stimulating the diseased retina with weak currents can activate signalling pathways and the release of substances that have a protective effect on the retinal cells. This neuroprotective effect can preserve the physiological functions of the retina for longer and slow down its gradual degeneration. To maintain this effect, long-term use is necessary.

In TES therapy, retinal stimulation is achieved through transcorneal electrical stimulation: A thread electrode, the OkuEI M, is used to apply a weak current (≤ 0.95 mA) to the surface of the eye, which spreads through the eye towards the retina.

System components – Images and description of OkuStim 2

(Note: The illustrations of the components may differ slightly from the actual products).

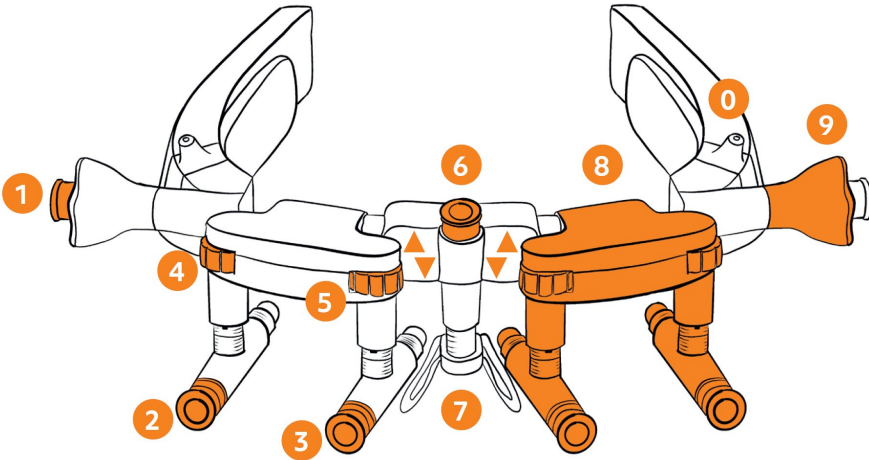

- (1, 2, 3) Pull-fix knobs
- (4–5) Knobs
- (6) Nose pad height adjustment pull-fix knob
- (7) Nose pad (3 different sizes)
- (8) Electrode holder
- (9) Rotary handle
- (0) Connection of return electrode cable
- ▼ 4 info-LEDs

Fig. 1-1: OkuStim 2 complete view

Left side

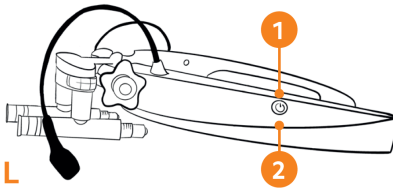

- (1) On/off button
- (2) status LED
(below the on/off button)

Right side

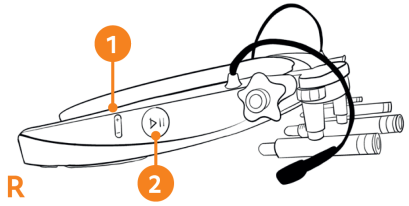

- (1) [+/-] button
- (2) Start/pause button

OkuStim 2 from above

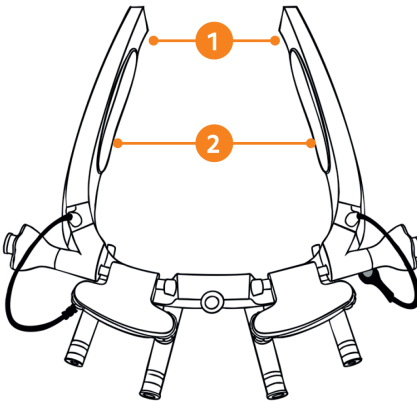

- (1) Eyelet for headband, on both sides
- (2) Speaker, one in each bracket.

OkuStim 2 from below

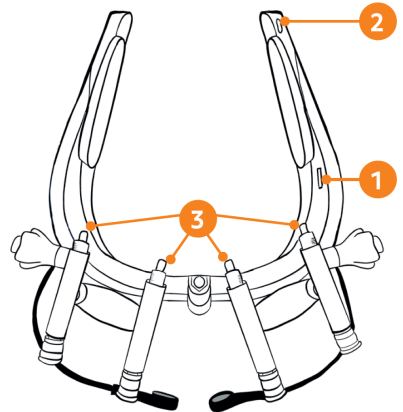

- (1) Slot for memory card
- (2) USB-C socket for charging
- (3) Magnetic electrode holder with scaling

Fig. 1-2: OkuStim 2 left/right/up/down

1.1 Control knobs and setting options

Pull-fix knobs

The states of the pull-fix knobs are shown below:

Fixed state

(no adjustment possible)

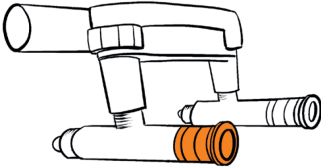

Extended state

(can be adjusted)

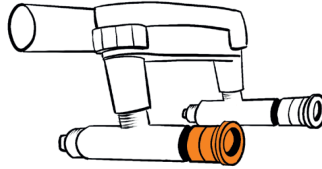

Fig. 1.1-1: OkuStim 2 pull-fix knobs

When pulled out, the electrode holder can be adjusted. When the knob is pushed back in, no adjustment is possible.

Knobs

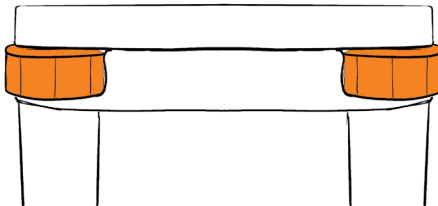

Fig. 1.1-2: OkuStim 2 knobs

No mechanical fixing is possible with the knobs. Free play prevents small rotational movements.



Warning notice:

There is a possibility that the settings could change if accidentally turned.

Adjustment options for OkuStim 2

OkuStim 2 can be easily adapted to the user's individual face shape. Annex 1, A.1 uses a defined coordinate system to show the directions of possible movements of the various components of OkuStim 2, which can be adjusted depending on the anatomy of the patient's face.

Description/definition of the positions (swivel mechanism)

The electrode holders of OkuStim 2 can be moved into three different positions using the rotary handles (see Fig. 1.1-3). Always perform the turning movements in a controlled manner. The rotary handle must not be let go uncontrolled.

Position 2 (open)

Select this position to attach the OkuEI M electrodes to the electrode holders and to put OkuStim 2 on the head.

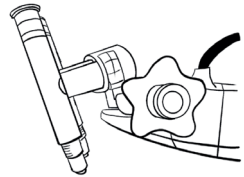

Position 1 (intermediate step)

This intermediate step gives the patient more control when applying/swivelling the OkuEI M.

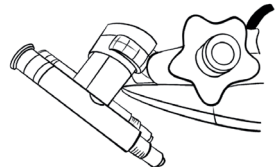

Position 0 (closed, at the eye)

Position during stimulation.

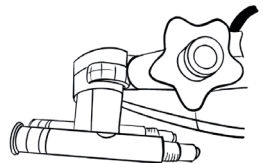

Fig. 1.1-3: OkuStim 2 electrode holder positions

1.2 OkuEI M

The OkuEI M is a disposable electrode. It consists of two caps with two fine silver threads that are placed on the surface of the eye (conjunctiva) below the pupil.



The OkuEI M is magnetically connected to the electrode holders. The OkuEI M can be attached to the electrode holder of the OkuStim 2 with the aid of the OkuEI M blister pack.

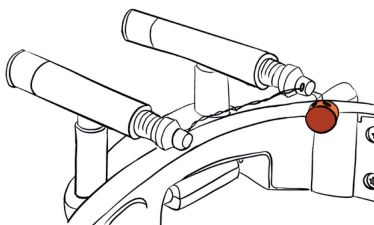

Fig. 1.2-1: OkuEI M

OkuEI counter electrode

The OkuEI counter electrode is a disposable adhesive electrode.

For hygiene reasons, OkuEI M and OkuEI counter electrodes may only be used once.

2 Therapy

After switching on OkuStim 2, the retina is electrically stimulated at the set intensity for a fixed period of 30 minutes. This can lead to the perception of whitish flickering light (so-called "phosphenes").

The individual stimulation parameters are determined in advance for each patient by healthcare professionals and saved on OkuStim 2.

Data generated during stimulation, such as resistance values, are recorded on the memory card. This also allows healthcare professionals to monitor the course of treatment.

OkuStim 2 has five LEDs and an audio output that provide information about all essential operating states of the device, so that even patients with advanced visual impairment can use it independently without any problems.

Chapter 9 contains explanations of the different operating states (audio outputs and LEDs).

3 Scope of delivery of the OkuStim 2 system

Your OkuStim 2 system comes in a sturdy transport box, which also serves as storage for the individual system components. After use, place OkuStim 2 back into the box.

The OkuStim 2 system is available in different versions.

Possible scope of delivery of the OkuStim 2 system:

- **OkuStim® 2** (on the product label: OkuStim® 2, item no.: OK200008)
- **Charging cable** (on the product label: OkuStim 2 USB Cable, item no.: OK000022)
- **USB charger** (on the product label: OkuStim 2 Power Adapter EU/UK/US, item no.: OK000028/OK000029/OK000030)
- **Headband** (on the product label: OkuStim 2 Headband, item no.: OK000134)
- **Nose bridges** (on the product label: OkuStim 2 Nose pad S/L, item no.: OK000135/OK000137)
- **Instructions for use**
- **Screwdriver** (on the product label: OkuStim 2 TX3, item no.: OK000132)

Other items required (not included in the scope of delivery):

- **OkuEI® M electrode package** (on the product label: OkuEI® M Package, item no.: OK200004)
 - 12 OkuEI® M (on the product label: OkuEI® M, item no.: OK200003)
 - 12 OkuEI® counter electrodes (on the product label: OkuEI® Counter Electrode, item no.: OK100052)

4 Information before first use

- The individual therapy parameters must be determined and set by a healthcare professional before starting the therapy.
- It is recommended that patients use eye drops during the use of TES therapy with OkuStim 2.
- Patients with limited mobility (e.g. advanced rheumatism, Parkinson's disease) may require assistance when using TES therapy with OkuStim 2.
- Have OkuStim 2 individually adapted for you. For a nose bridge replacement, please contact your dealer or doctor.
- If you encounter any difficulties, please contact your doctor or the dealer from whom you purchased the OkuStim 2 system.
- Arrange regular check-ups with your doctor to monitor the course of treatment.
- Please leave the memory card in OkuStim 2. Only trained service personnel are authorised to remove it.

Before you can use OkuStim 2 at home, the following steps must be carried out by your doctor or dealer:

- The electrode holders are adjusted to fit the shape of your head and eyes.
- Your individual therapy parameters are transferred to the OkuStim 2 device.
- You will learn how to use OkuStim 2 in a training session.

Your doctor or dealer will discuss the procedure with you and advise on further steps.

5 Step-by-step instructions: Stimulation by the patient themselves

Please carefully follow the steps for preparing and conducting a therapy session. Otherwise, spontaneous and intense phosphene perception (flickering lights) may occur.

Always use the specified stimulation strength for stimulation. This is used automatically every time the system is restarted.

Only reduce the stimulation strength in exceptional cases (using the +/- button on the right-hand side). During stimulation, you can also use this button to reset the stimulation strength to the initial level. If you find the stimulation strength too strong, consult your doctor or dealer.

Step-by-step description

Images and notes

Preparation:

- Place the storage box containing OkuStim 2 and the OkuEI M package on a table or other suitable flat surface.

Attach the OkuEI counter electrodes to the forehead:

- Thoroughly clean the skin on the left and right sides of the forehead with an alcohol swab before attaching the OkuEI counter electrodes.
- Wait briefly until the skin is dry.
- Take a counter electrode package from the OkuEI M package.
- Open the OkuEI counter electrode packaging carefully without tearing it.
- Remove a counter electrode from the transparent backing film.

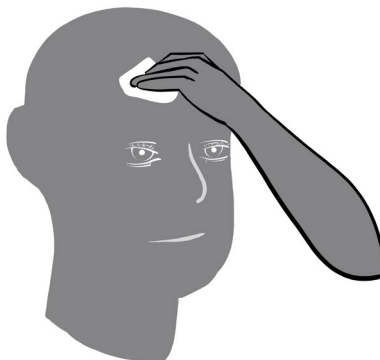

- Stick the OkuEI counter electrode onto the area where the forehead has been thoroughly cleaned. Make sure that the entire surface of the counter electrode is adhered smoothly and completely.
- Remove and stick the second counter electrode onto the second cleaned area on the forehead.
- Seal the OkuEI counter electrode packaging as airtight as possible.

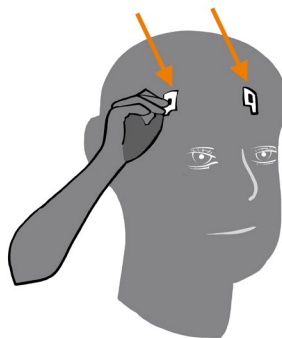

Notes:

- The ideal position for the counter electrodes is on the right and left sides of the forehead between the eyebrows and hairline.
- To attach the counter electrodes, the position can be checked in a mirror or with a mobile phone camera.
- After removing the counter electrodes, reseal the outer packaging as airtight as possible. This prevents the remaining counter electrodes from drying out. Adhesive tape or a kitchen clip is suitable for this.

Unpack OkuStim 2:

- Remove OkuStim 2 from the storage box.
- Place OkuStim 2 upside down on a dry surface. The two brackets point away from you.

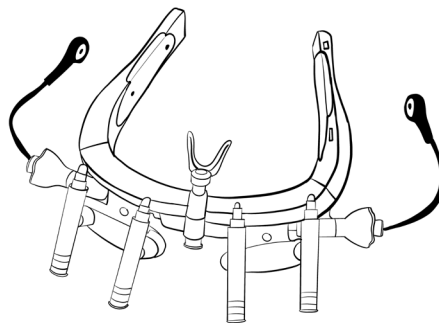

Notes:

- Make sure that the two electrode holders are opened as shown in the picture (position 2).
- If you accidentally switch on OkuStim 2 while unpacking it, switch it off again by pressing the on/off button on the left bracket for at least 2 seconds.

Insert the OkuEI M electrodes:

- Remove two OkuEI M blister packs from the OkuEI M package.
- Completely tear open the seal cover of the first OkuEI M blister pack, taking care not to touch the electrode thread.
- Hold the open blister pack at the pointed end.
- Place the first OkuEI M (using the blister pack) on the first magnetic electrode holder of OkuStim 2. First attach the outer side (white cap next to the orange seal) and then the inner side. The orange seal points outwards (away from the nose bridge).

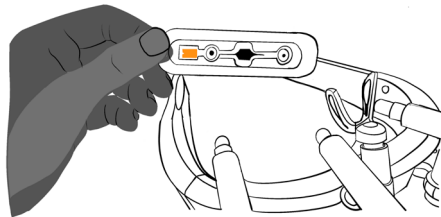
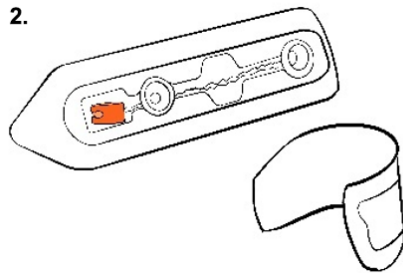
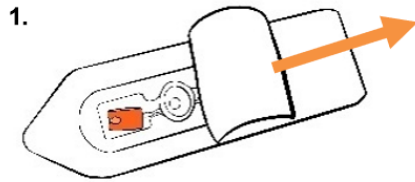

- The OkuEI M is magnetically attracted to the electrode holder. Ideally, you should hear a clicking sound when attaching it.
- Carefully pull off the blister pack, ensuring that both sides of the OkuEI M remain attached.
- Repeat the above for attaching the second OkuEI M.

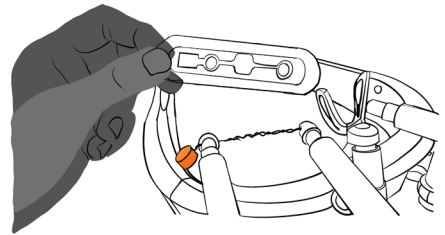
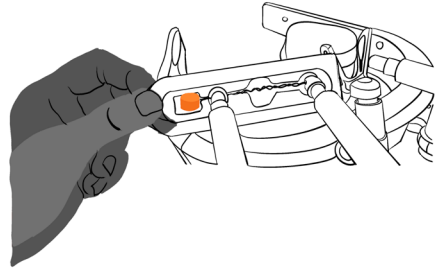

Notes:

- The OkuEI M are individually packaged in blister packs.
- The blister pack also serves as a guide for attaching the electrode to the magnetic electrode holder easily and without touching it.

Prepare your eyes and sitting position:

- Lubricate your eyes with eye drops.

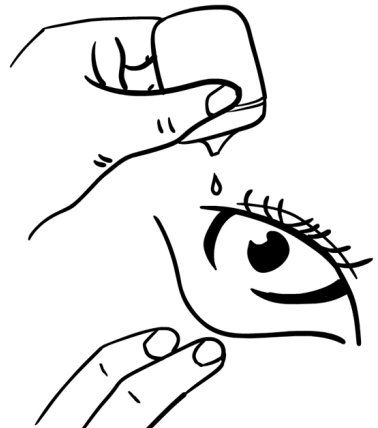

- Assume a comfortable and stable sitting position. Ideally, the head or entire upper body should be reclined.

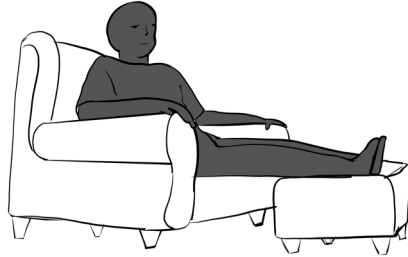

Note:

- During a stimulation session, the eyes should always be well lubricated.

Switching OkuStim 2 on and positioning it:

- Switch on OkuStim 2. To do this, press and hold the on/off button on the left bracket for at least 2 seconds.
- Put on OkuStim 2.

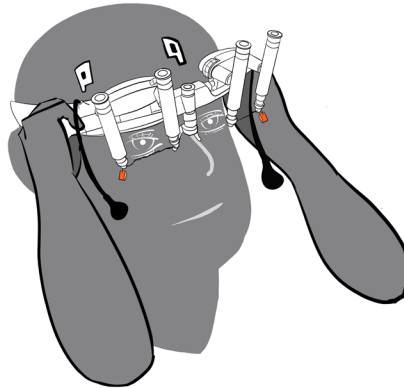
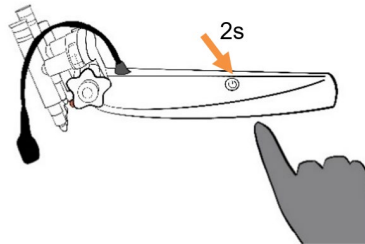

- Connect the two OkuEI counter electrodes to the cables on OkuStim 2.

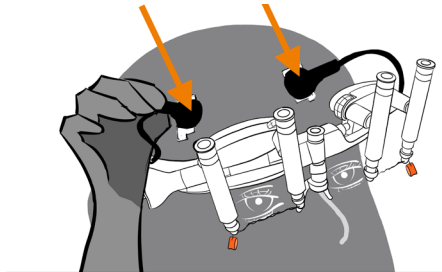
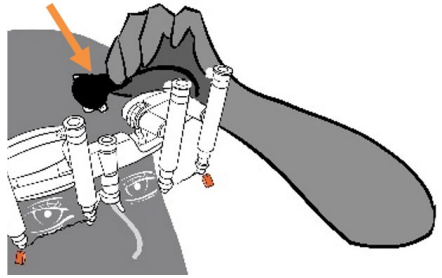

Notes:

- When successfully switched on, OkuStim 2 emits a start-up tone and the LEDs flash white.
- If the position of OkuStim 2 makes it difficult to press the snap connectors on the counter electrode cables, OkuStim 2 can first be moved forward slightly on the nose to provide more space. After connecting the OkuEI counter electrodes, OkuStim 2 can then be repositioned against the forehead.
- Ensure that OkuStim 2 does not slip after putting it on – deep cushions can push OkuStim 2 forward.

- If you accidentally press the start/pause button, you can pause the stimulation by pressing it again until you are ready.

Swivel the OkuEI M into position:

- If you have been advised to use the OkuStim 2 headband for greater comfort and stability, you should now tighten it so that OkuStim 2 does not slip off your nose and remains in the same position throughout the stimulation session.
- Use the rotary handle on the side of OkuStim 2 to position the electrode holder with the inserted OkuEI M towards the eye.
- With one hand, gently pull down the lower eyelid while the eye is open to prevent the OkuEI M electrode from catching on the eyelashes when you move the electrode holder into position.
- Always look upwards when bringing the OkuEI M electrode close to the eye.
- Repeat the above procedure (points 2 to 4) for the other eye.

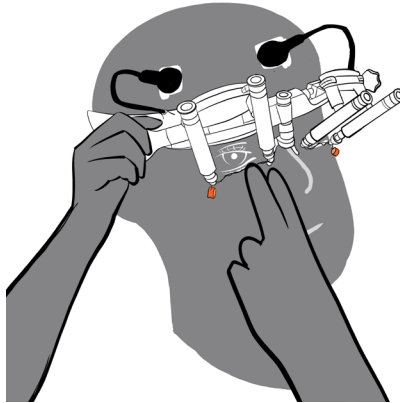
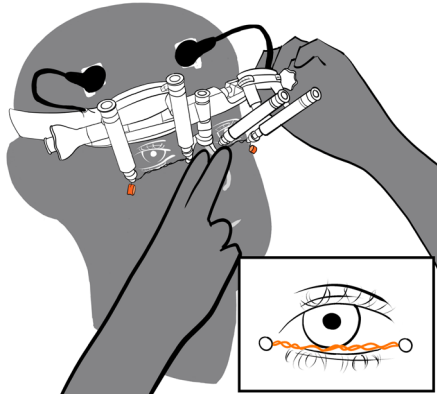

- You can now close your eyes and keep them closed during the stimulation.

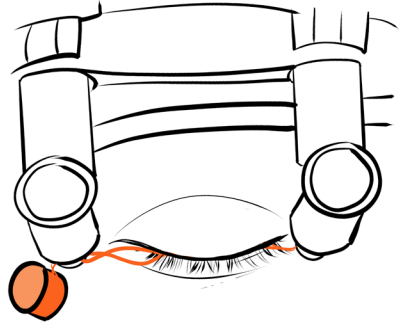

Note:

- Ensure that the OkuEI M makes good contact with the eye. The contact length of the electrode thread on the surface of the eye (conjunctiva) should be at least 1 cm.

Stimulation:

- Start stimulation. To do this, press the start/pause button on the right-hand side of OkuStim 2.
- During the 30-minute therapy session, keep your eyes closed and your head still and slightly reclined.

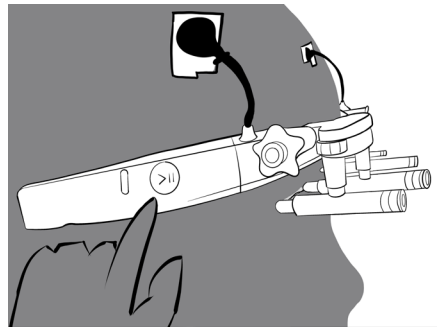

Notes:

- To indicate the progress of the session, OkuStim 2 emits a short beep every 10 minutes.
 - The ongoing stimulation is indicated by a ticking sound.
-

Functions during stimulation:**Pause**

- You can pause the stimulation with the start/pause button if required. The pause status is indicated by two short, recurring tones. The stimulation time is paused for the duration of the pause and continues when it resumes.
- To continue your stimulation session, press the start/pause button again.

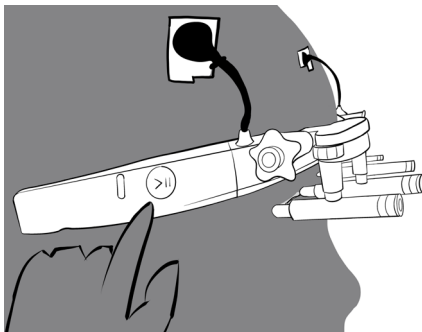
**Notes:**

- Please note that OkuStim 2 switches off automatically after 10 minutes in pause mode. The stimulation time then starts again when the device is switched on again.
 - You have the option (e.g. in case of pain) to reduce the current strength using the +/- button on the right-hand side of OkuStim 2. Only reduce the current in exceptional cases. If you need to reduce the current regularly, please consult your doctor.
-

End of stimulation:

- Once the programmed stimulation time has elapsed, the device stops automatically and signals this with a slightly longer, more noticeable tone.
- Open your eyes and remove the two OkuEI M electrodes from your eyes using the two side-mounted rotary handles on OkuStim 2.
- Disconnect the two cables from the OkuEI counter electrodes by carefully pulling them off the snap connectors.

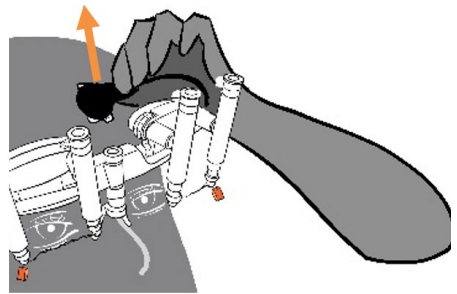
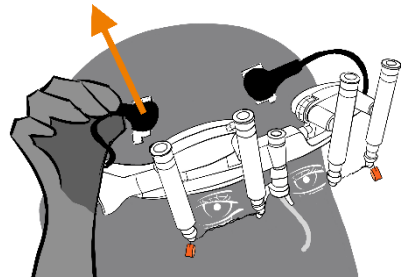
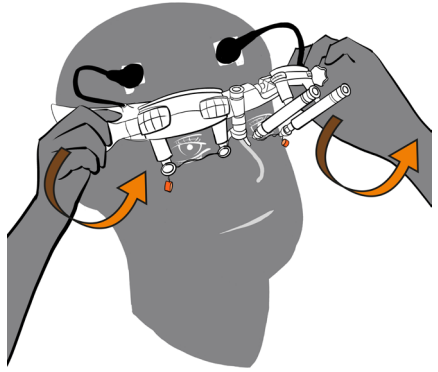

- Remove OkuStim 2 from the head.

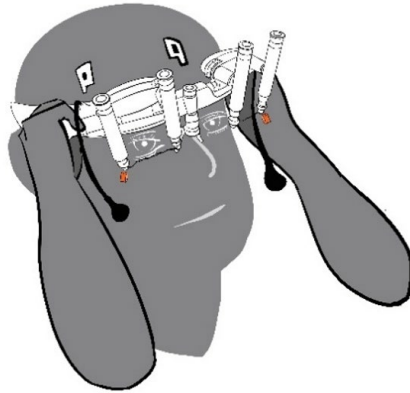

Note:

- Never pull on the counter electrode cables, as they could break.

After the stimulation:

- Switch off OkuStim 2. To do this, press the on/off button on the left bracket for at least 2 seconds.
- Remove the used OkuEI M from the electrode holders and dispose of them in the general waste.

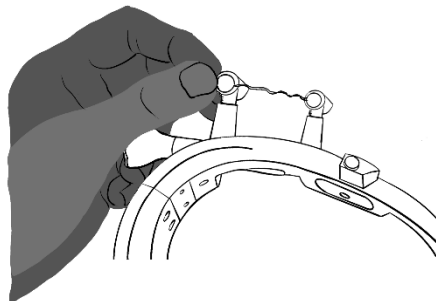
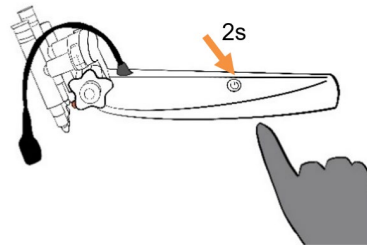

- Remove the OkuEI counter electrodes from the skin by carefully peeling them off and dispose of them in the general waste.
- Recharge OkuStim 2 for at least 2 hours using the power supply unit provided.
- Put OkuStim 2 back into the storage box.

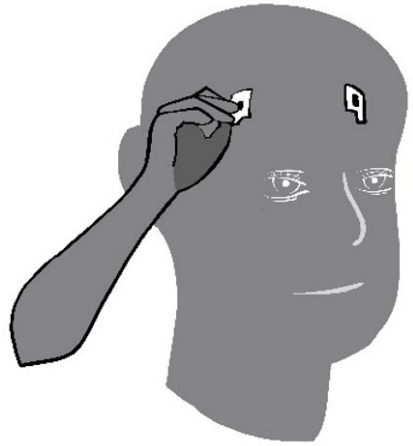

Notes:

- Five minutes after the end of the therapy session, OkuStim 2 switches off automatically – in case you forget to switch it off using the on/off button.
- Clean OkuStim 2 regularly. You will find more information on this in chapter 7.
- You will find further information on charging OkuStim 2 in chapter 6.

Table 1.2-1: Step-by-step instructions

6 Charging OkuStim 2

Charge OkuStim 2 if the 4 info LEDs light up red after switching on and the device switches off automatically again.

Connect the device to a power socket using the supplied USB charging cable and charger. .

To check the charge status, press the on/off button. If the status LED flashes red, OkuStim 2 is charging. If the LED lights up green continuously, OkuStim 2 is fully charged.

Wait until the battery is fully charged before disconnecting OkuStim 2 from the power supply.

Stimulation is not possible during charging.



Warning notice:

Do not charge OkuStim 2 with any charger or charging cable other than the one supplied.

OkuStim 2 must not be worn on the head while charging.

Depending on the ambient temperature, the OkuStim 2 housing may become very hot during charging. Therefore, after removing the cable, wait 10 minutes for the device to cool down before putting on and using OkuStim 2.

7 Disinfection and cleaning

Cleaning

Switch off the device before cleaning.

Clean OkuStim 2 with a soft, lint-free cloth. The cloth should be damp, never wet. Make sure that no moisture gets inside the device. If moisture has entered the device, it must undergo a safety inspection before being used again. If necessary, contact your optician or dealer.

When cleaning, also pay attention to the magnets to which the OkuEI M is attached.

Ferromagnetic particles that adhere to the magnetic electrode holder can be removed using adhesive tape.

(For healthcare professionals) Clean OkuStim 2 after each patient use.

Disinfection

We recommend the following for wipe disinfection of OkuStim 2:

Schülke mikrozyd sensitive wipes premium

Schülke & Mayr GmbH, Robert-Koch Straße 2, 22851 Norderstedt, Germany

Thoroughly wipe the surface with disinfectant wipes. Ensure that the surface is completely moistened. The surface must remain moist during the entire application time. For sufficient disinfection, there must be enough active ingredient on the surface.



Warning notice:

Please do not use aggressive, chlorinated, abrasive or harsh cleaning agents. Gasoline, alcohol, ether or solvents must not be used. Cleaning in an ultrasonic bath is not allowed.

OkuEI M and OkuEI counter electrode

The OkuEI M and OkuEI counter electrodes are single-use items and must not be reused for hygienic and technical reasons.

8 Side effects

Common side effects of the therapy include temporary symptoms of dry eye and/or a foreign body sensation during stimulation (in studies, in >70% of treated patients). In these cases, standard eye drops usually help. In addition, patients often report temporary reddening of the eye and/or the area where the counter electrode was attached. Other side effects that occurred in clinical trials or were reported by regular users of the therapy are listed in the following table.

Side effect	Frequency
Electric shock sensation/itching/burning/pain or other discomfort on or in the eye during therapy	10–50
(Partially subjective) deterioration of visual acuity or disturbances in visual perception	50–100
Headache/other discomfort in the head or at the counter electrode	50–100
Cataract	100–200
Macular oedema	100–200
Retinoschisis or retinal cysts	200–400
Increased tear production	200–400
Nausea/feeling faint/dizziness	200–400
Change in the lens	>400
Gliososis	>400

Table 1.2-1: Side effects of TES therapy with OkuStim 2

The frequency indicates the number of user-years in which a side effect occurred once. A frequency of 10 means that the side effect occurred once in 10 years of therapy use.

Contact your doctor if you notice any side effects that concern you, or if certain symptoms – such as temporary redness of the eyes – persist for longer than 1–2 days.

If events occur that are listed as contraindications (e.g. pregnancy), TES therapy must be discontinued. In this case, inform your doctor.

9 Light and sound signals

When OkuStim 2 is switched on, an automatic system check is performed. All indicators (LED + acoustic) are activated according to a specific pattern to determine whether they are functioning properly.

Sound signal	Description
10 minute interval (during stimulation)	3 quick clicks, last click ascending
Volume	1 low tone
Connected	3 quick clicks, ascending
Error: Contact counter electrode	2 double tones, low - high (with echo)
Error: Contact electrode	2 double tones, high - low (with echo)
Not connected	3 quick clicks, descending
Lower limit (stimulation/volume)	4 low clicks, last click descending
Minus	1 double tone low
Pause	2 slow clicks
Plus	1 double tone high
Switch off	3 clicks descending
Switch on	3 clicks ascending
Stimulation	1 click every 2 seconds
System error	1 low double tone (with echo)
Upper limit (stimulation/volume)	4 high clicks, last click ascending

Table 1.2-1: Description of the sound signals



Use the QR code to listen to the audio signals.

An Internet connection is required for this.

9.1 LED positions

For better readability, the following description is limited to the LEDs:

Front LEDs

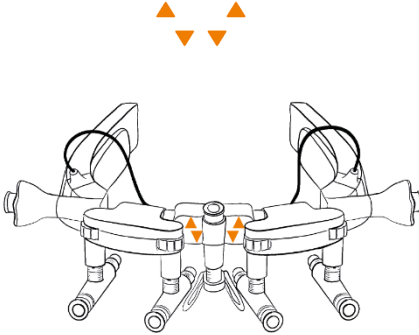

Side LED

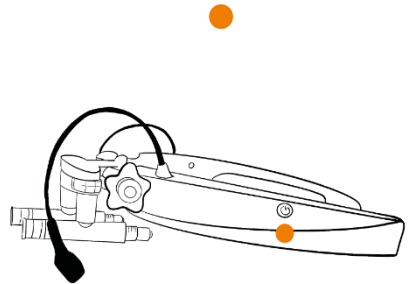
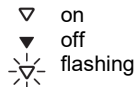

Fig. 9.1-1: LED positions

Please note:

- The side LED is not displayed when it is inactive.
- The colour representation of the LEDs in the instructions for use may differ slightly from reality.
- Display of LED operating states:



Example 1:

The top two and the side LED flash white. The lower ones are inactive.



Example 2:

The front LEDs all light up green for 3 seconds.



9.2 Button functions and light and sound signals

This chapter contains tables summarising the actions that can be performed using the buttons on OkuStim 2. In addition, the respective feedback is described in the form of light and sound signals (for these actions).

As OkuStim 2 can be set to different operating modes, the actions, button functions and corresponding sound and light signals are shown separately for each operating mode.

Switching on OkuStim 2









OkuStim 2 is switched off and is switched on			
Action	Buttons	Light signal	Sound signal
Switching on the device and displaying the battery status	Press the on/off button for at least 2 seconds	 <p>Fig. Side LED flashes white briefly when switched on.</p> <p>When the battery is sufficiently charged for a 30-minute stimulation session, the device displays the following light signal:</p>  <p>Fig. The LEDs on the front flash white from left to right once in quick succession (top left, bottom left, bottom right, top right).</p> <p>Afterwards:</p>  <p>Fig. The top two LEDs at the front and the side LED flash white.</p> <p>The device is ready for stimulation.</p>	3 clicks ascending
		<p>If the battery is not sufficiently charged, the device will display the following light signal instead:</p>  <p>Fig. The front LEDs flash red three times. The system switches itself off.</p>	

Table 9.2-1: Switching on OkuStim 2

Functions during ongoing stimulation

Stimulation is currently running with OkuStim 2 (stimulation mode)			
Action	Button	Light signal	Sound signal
Stimulation running (no action)	-	 <p>Fig. Side LED flashes white.</p>	1 click every 2 seconds; Additionally, every 10 minutes: 3 quick clicks, last click ascending
Reduce the stimulation strength	Press the - button	-	1 double tone low; When the lower limit value is reached: 4 low clicks, last click descending
Increasing the stimulation strength	Press the + button	-	1 double tone high; When the upper limit value is reached: 4 high clicks, last click ascending
Pause during stimulation or during a resistance error	Press the start/pause button	 <p>Fig. Top LEDs at the front and side flash white.</p> <p>For healthcare professionals only: When the device is connected to and controlled by the OkuStim Pulse software, the LEDs flash blue.</p>	2 slow clicks, repeated
Continue stimulation	Press the start/pause button	 <p>Fig. Side LED flashes white.</p> <p>For healthcare professionals only: When the device is connected to and controlled by the OkuStim Pulse software, the LED flashes blue.</p>	1 click every 2 seconds; Additionally, every 10 minutes: 3 quick clicks, last click ascending
Early termination of the stimulation session	Press the start/pause button to pause the stimulation. Then press and hold the on/off button for at least 2 seconds to switch off OkuStim 2.	 <p>Fig. Top LEDs at the front and side flash white.</p> <p>If the battery is sufficiently charged for a 30-minute stimulation session when switched off, the device displays the following light signal:</p>	2 slow clicks when pausing and then when switching off 3 clicks descending
		<p>3sec</p>  <p>Fig. The front LEDs light up green for 3 seconds.</p>	



		<p>If the battery is not sufficiently charged when switching off, the device will instead display the following light signal:</p>  <p>Fig. The front LEDs flash red three times.</p>	
Stimulation ends (no action)	-	 <p>Fig. The top two LEDs at the front and the side LED flash white = standby mode.</p>	3 quick clicks, as with the '10-minute message', but twice in succession

Table 9.2-2: Functions during ongoing stimulation

Functions after switching on

Standby and battery status



OkuStim 2 is switched on, but no stimulation (or pause) has been started (standby mode)			
Action	Buttons	Light signal	Sound signal
Device is ready for stimulation (or can be switched off).	-	 <p>Fig. The two upper LEDs at the front and the side LED flash white.</p>	-
Check battery status	Press the + and - buttons simultaneously for at least 2 seconds	<p>When the battery is sufficiently charged for a 30-minute stimulation session, the device displays the following light signal:</p>  <p>Fig. The front LEDs light up green for 3 seconds.</p> <p>If the battery is not sufficiently charged, the device will display the following light signal instead:</p>  <p>Fig. The front LEDs flash red three times.</p>	-

Table 9.2-3: Standby and battery status

Volume setting

OkuStim 2 is in standby mode			
Action	Button	Light signal	Sound signal
Change volume setting	Press + or - button for at least 2 seconds.	-	1 low tone repeated
Increase volume	Press the + button	-	1 double tone high (louder with each press of the button); When the upper limit value is reached: 4 high clicks, last click ascending
Reduce volume	Press the - button	-	1 double tone low (quieter with each key press) When the lower limit value is reached: 4 low clicks, last click descending
Exiting and saving the volume setting	No action for at least 5 seconds	-	1 low tone twice in quick succession

Table 9.2-4: Volume setting

Switching off OkuStim 2



OkuStim 2 is in standby mode			
Action	Buttons	Light signal	Sound signal
Switching off the device and displaying the battery status (also during charging)	Press the on/off button for at least 2 seconds Or: No action for at least 5 minutes	When the battery is sufficiently charged for a 30-minute stimulation session, the device displays the following light signal: <div style="text-align: center;">  <p>3sec</p> </div> <p><small>Fig. All front LEDs light up green for 3 seconds.</small></p>	3 clicks descending
		If the battery is not sufficiently charged, the device will display the following light signal instead: <div style="text-align: center;">  <p>3x</p> </div> <p><small>Fig. The front LEDs flash red three times.</small></p>	

Table 9.2-5: Switching off OkuStim 2

Charging OkuStim 2

The charge status of OkuStim 2 can be checked during charging (cable connected).





OkuStim 2 is switched off and in charging mode (charging cable plugged in).			
Action	Buttons	Light signal	Sound signal
Check the charge status during charging	Press the on/off button for at least 2 seconds	<p>When switching on:</p>  <p>Fig. Side LED flashes white briefly when switched on.</p> <p>Afterwards:</p>  <p>Fig. The LEDs flash white from left to right at the front, one after the other in quick succession (top left, bottom left, bottom right, top right).</p> <p>Afterwards:</p> <p>During charging:</p>  <p>Fig. Side LED flashes red.</p> <p>The OkuStim 2 is fully charged:</p>  <p>Fig. Side LED lights up green (continuous light).</p>	3 clicks ascending

Table 9.2-6: Charging OkuStim 2

9.3 For healthcare professionals: Additional button functions, light and sound signals

Set OkuStim 2 to pairing mode for connection with the OkuStim Pulse software

OkuStim 2 is switched off and will be switched on for pairing mode			
Action	Button	Light signal	Sound signal
Set the device to pairing mode	Press the on/off button for at least 6 seconds.	 <p>Fig. The side LED initially lights up white for a few seconds and then flashes blue.</p>	3 clicks ascending

Table 9.3-1: Set OkuStim 2 to pairing mode for connection with the OkuStim Pulse software

Control functions in the OkuStim Pulse software



OkuStim 2 is in pairing mode			
Action	Button	Light signal	Sound signal
Successfully connected to the software	Activation of pairing mode in the software	 Fig. Top LEDs at the front and side flash blue.	3 quick clicks, ascending
Device ready for use with the OkuStim Pulse	-	 Fig. Top LEDs at the front and side flash blue.	-
Starting stimulation in the software for threshold detection or test stimulation	Starting the stimulation in the software	 Fig. Side LED flashes blue	1 click every 2 seconds continuously and every 10 minutes: 3 quick clicks, last note ascending

Table 9.3-2: Control functions in the OkuStim Pulse software

Exiting pairing mode and switching off OkuStim 2

OkuStim 2 is in pairing mode			
Action	Button	Light signal	Sound signal
Switching off the system/exiting pairing	Press the on/off button for at least 2 seconds Or: Exit pairing in the software Or: No action for at least 7 minutes	-	3 quick clicks, descending

Table 9.3-3: Exiting pairing mode and switching off OkuStim 2

10 Storage

OkuStim 2

Store OkuStim 2 in the box supplied.

Handle the entire system with care to avoid damaging the electronics or causing other malfunctions.

Do not expose OkuStim 2, OkuEI M or OkuEI counter electrodes to excessive moisture, heat, cold or contamination.

Switch off the device before cleaning.

Never immerse the device and its accessories in water or expose it to excessive moisture.

Handling the OkuEI M Package

Handle the OkuEI M package and its contents with care to avoid damaging the components.

Storing the OkuEI M

The OkuEI counter electrodes and the OkuEI M are stored in the OkuEI M package.

The OkuEI M OK200003 are individually packaged in blister packs in the OkuEI M Package.

The expiry date of the OkuEI M is printed on the lid of the individual blister packs.

The storage temperature of the OkuEI M is noted on the label on the front of the individual packaging.

Storage of the OkuEI counter electrodes

The OkuEI counter electrodes are supplied in packs of three pieces each on a backing foil, as part of the OkuEI M package.

The expiry date of the OkuEI counter electrodes is shown on the label on the front of the OkuEI M Package. The storage temperature of the OkuEI counter electrodes is 5 °C - 40 °C.

After removing the OkuEI counter electrodes, the packaging should be resealed by folding the torn side to protect the remaining electrodes from drying out.

11 Repair and maintenance

The device is maintenance-free for private use. Commercial users must comply with the relevant legal requirements for the operation of medical electrical equipment.



Warning notice:

Do not attempt to repair or maintain the device yourself. Instead, contact your optician or dealer.

Screws must not be loosened. Batteries may only be replaced by qualified personnel.

Contact your dealer.

12 Error handling

If OkuStim 2 is not functioning correctly, this will be indicated by acoustic signals and LEDs. Below you will find an overview of the possible errors and what to do to rectify them.

If OkuStim 2 is damaged, please contact your dealer.

Electrical resistance

The electrical resistance between the patient (eye, forehead) and the OkuStim 2 system (electrode thread, counter electrode) varies from user to user and changes during stimulation. It is normal to feel the flow of electricity. Some users may find this unpleasant. However, this is no reason to stop the stimulation. Nevertheless, the therapy should not be painful.

If the resistance is too high, OkuStim 2 automatically indicates this with sound and light signals. If the resistance increases during use to such an extent that the stimulation is perceived as painful or OkuStim 2 emits a sound signal, please follow the instructions in Table 12-1.

In the event of a resistance error (resistance too high), OkuStim 2 automatically interrupts the stimulation. In this case, the stimulation should be paused by pressing the start/pause button. Resume the stimulation after you have corrected the issue. If the sound signal persists or the stimulation remains painful, please contact your dealer.

What is a system error?

System errors indicate a technical error. If the error cannot be rectified by following the steps in Table 12-3, please contact your dealer directly.

Dark-coloured OkuEI M

The silver threads of the OkuEI M can appear in different shades of grey and waves, which also change during stimulation. This is normal and may affect the resistance of the electrodes. You can use electrodes with dark-coloured silver threads as long as they have not passed their expiry date.

The OkuEI M must never be used more than once.

Overview and solutions for error handling

Note on the following tables: The colour representation of the LEDs in the instructions for use may differ from reality.

Errors during stimulation

Error message/problem	Solution
-----------------------	----------



OR



- The LED at the top flashes red on the side of the error.

1. Pause the stimulation. (Press the start/pause button.)
2. After each of the following steps, check whether this resolves the error by resuming the stimulation (pressing the start/pause button). Pause again if necessary:
 - Check that the counter electrode cable has been connected correctly.
 - Check that the counter electrode is fully in contact with the skin.

- A sound sequence can be heard on the side of the error: 2 double tones low – high (with echo)
- Switch OkuStim 2 off and on again.
- Degrease the skin again and stick a new counter electrode onto the skin. Then connect the counter electrode cable to the counter electrode.
- In the event of sweating: If necessary, carry out the therapy in a room with an adequate temperature.



- Both LEDs at the top flash red.
- The sound sequence can be heard on both sides of the error: 2 double tones low – high (with echo)



OR



- LED at the bottom flashes red on the side of the error
- A tone sequence can be heard on the side of the error: 2 double tones high – low (with echo)
- 1. Pause the stimulation. (Press the start/pause button.)
- 2. After each of the following steps, check whether this leads to the error being rectified by resuming the stimulation (press the start/pause button). Pause again if necessary:
 - Check the fit of OkuStim 2 (e.g. is the device positioned correctly on the nose and in contact with the forehead?).
 - Fold the electrode holder up and down to the eye. Remember to pull down the eyelid. Also make sure that no eyelashes get caught in the electrode thread.
 - Moisten the eyes again with eye drops.

- Check the contact length of the electrode thread with the surface of the eye (conjunctiva). This should be at least 1 cm,
- Check that the OkuEI M is correctly seated in its holder. First make sure that the orange seal is facing outwards. Also check that the OkuEI M is correctly seated in its holder, especially in the holder on the side of the nose.
- Make sure that you always keep your head slightly reclined and that OkuStim 2 does not slip forwards.
- If the problem persists, please contact your dealer.

For medical professionals and dealers only:

- Annex 1, A.4 contains further options for rectifying the error. These measures may only be carried out by trained specialist personnel.



- Both LEDs at the bottom flash red.
- The tone sequence can be heard on both sides of the error: 2 double tones high – low (with echo)

- Proceed exactly as described above. However, check both electrode holders and both OkuEI M.



OR

1. Pause the stimulation. (Press the start/pause button.)
2. After each of the following steps, check whether this resolves the error by resuming the stimulation (pressing the start/pause button). Pause again if necessary:

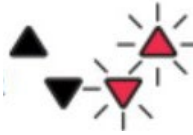

- LEDs at the top and bottom flash red on the side of the error.
- A tone sequence can be heard on the side of the error: 2 double tones high – low (with echo)

- Check the fit of OkuStim 2 (e.g. is the device positioned correctly on the nose and in contact with the forehead?).
- Move/swivel the electrode holder up and down. Remember to pull down the eyelid. Also make sure that the electrode thread does catch the eyelashes.
- Lubricate the eye again with eye drops.
- Check the contact length of the electrode thread with the surface of the eye (conjunctiva). This should be at least 1 cm.
- Check that the OkuEI M is correctly attached to its holder, especially in the holder on the side of the nose. Also make sure that the orange seal is facing outwards.
- Make sure that you always keep your head slightly reclined and that OkuStim 2 does not slip forwards.
- Check that the counter electrode cable has been connected correctly.
- Check that the counter electrode is fully in contact with the skin.
- Switch OkuStim 2 off and on again.
- Degrease the skin again and stick a new counter electrode onto the skin.

Then connect the counter electrode cable to the counter electrode.

- In case of sweating: If necessary, carry out the therapy in a room with an adequate temperature.

For healthcare professionals and dealers only:

- Annex 1, A.4 contains further options for rectifying the error. These measures may only be carried out by trained specialist personnel.

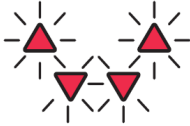

- Proceed exactly as described above.
But check both sides.

- All LEDs at the top and bottom flash red.
- Sound sequence can be heard on both sides:
2 double tones high – low (with echo)

Table 12-1: Errors during stimulation

Painful stimulation

Error message/problem	Solution
<p>Pain in the forehead: Stimulation is painful or more uncomfortable on the forehead than before.</p>	<ol style="list-style-type: none"> 1. Pause the stimulation until the cause of the problem has been rectified. 2. Check that the counter electrode is fully in contact with the skin. <p>If this does not solve the problem:</p> <ol style="list-style-type: none"> 3. Degrease the skin again and stick a new counter electrode onto the skin. Then connect the counter electrode cable to the counter electrode. <ul style="list-style-type: none"> • In the event of sweating: If necessary, carry out the therapy in a room with an adequate temperature. • If the problem persists, please contact your doctor or dealer.
<p>Pain in the eye: Stimulation is painful or more unpleasant on the eye than before.</p>	<ol style="list-style-type: none"> 1. Pause the stimulation. (Press the start/pause button.) 2. <u>After each of the following steps, check whether this resolves the issue by resuming the stimulation (pressing the Start/Pause button). Pause again if necessary:</u> <ul style="list-style-type: none"> • Check the fit of OkuStim 2 (e.g. is the device positioned correctly on the nose and in contact with the forehead?). • Swivel the electrode holder up and down. Remember to pull down the eyelid. Also make sure that the electrode thread does catch the eyelashes. • Moisten the eyes again with eye drops. • Check the contact length of the electrode thread with the surface of the eye (conjunctiva). This should be at least 1 cm,

- Make sure that you always keep your head slightly reclined and that OkuStim 2 does not slip forwards.
- If the problem persists, please contact your doctor or dealer.

Table 12-2: Painful stimulation

Functional problems	
Error message/ Problem	Solution
On/off button is stuck	<ol style="list-style-type: none"> 1. Free the stuck button (e.g. by pressing on the side that is not stuck). 2. Switch OkuStim 2 off and on again.
Despite sufficient charge, therapy cannot be started by pressing the start/pause button after switching on.	<ul style="list-style-type: none"> • Switch OkuStim 2 off and on again. When switching on, press and hold the on/off button for at least 2 seconds (but less than 6 seconds). • If the on/off button is stuck, free it (e.g. by pressing on the side that is not stuck). • If you are still unable to start the stimulation, contact your dealer.
OkuStim 2 cannot be switched on.	<ul style="list-style-type: none"> • Check the charge status: When the battery is empty, OkuStim 2 should be charged for at least 2 hours to enable a therapy session. • If the on/off button is stuck, free it (e.g. by pressing on the side that is not stuck). • If OkuStim 2 still does not switch on, please contact your dealer.
OkuStim 2 cannot be switched off.	<ol style="list-style-type: none"> 1. Free the stuck on/off or start/pause button (e.g. by pressing on the side that is not stuck).

2. Switch off OkuStim 2.

- If OkuStim 2 still cannot be switched off, please contact your dealer

When the start/pause button is pressed, the 4 LEDs at the front light up red for 2 seconds.



2 seconds

- All 4 LEDs at the front light up red for 2 seconds.
- Tone: 1 low double tone (with echo)

It is not permitted to start therapy by pressing the start/pause button while charging (with the cable plugged in):

1. Disconnect the cable connection to OkuStim 2.
2. Restart the therapy by pressing the start/pause button.

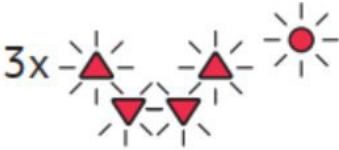

- Charge OkuStim 2 for at least 2 hours using the accessories supplied.

OkuStim 2 switches itself off again after being switched on.

- All 4 LEDs at the front and the one on the side flash red 3 times.
- Tone: 3 clicks, descending



- Switch OkuStim 2 off and on again.
- If the system error continues, please contact your dealer.

System error

- All 4 LEDs at the front light up red continuously.

- Sound: low double tone (with echo), in continuous loop

Defective OkuStim 2 components, e.g:

- Contact your dealer
- counter electrode cable or part of it is torn off.
- Swivel mechanism for the OkuEI M does not work.

Table 12-3: Functional problems

13 Technical data

The OkuStim 2 system is a Class IIa medical device in accordance with Annex VIII Rule 9 of the EU Medical Device Regulation (EU) 2017/745.

The OkuEI M is a Class IIa medical device according to Annex VIII Rule 5 of the EU Medical Device Regulation (EU) 2017/745.

The OkuEI counter electrode is a Class I medical device according to Annex VIII, Rule 1 of the EU Medical Device Regulation (EU) 2017/745.

13.1 Power supply

- Power supply 2x internal battery: Varta CP1454 A4X (3.7 V)

13.2 Connections

- Electrode connection: Connection to the OkuEI M and OkuEI counter electrode
- USB-C port.

13.3 Memory card

- Memory card (specially configured by Okuvision GmbH; included in the scope of delivery).

13.4 Housing

- Dust-protected (IP 22)
- Protection class: internally powered (battery-operated) Application part: Type BF

13.5 Service life

The OkuStim 2 system has an expected service life of 3 years. However, the OkuEI M and OkuEI counter electrodes have a different service life. This is indicated on the relevant label.

13.6 Operating conditions

Temperature:	+5 °C – +40 °C
Humidity:	15% - 93% relative humidity (non-condensing)
Air pressure:	540 hPa – 1060 hPa

13.7 Storage and transportation conditions

Temperature:	+5 °C – +40 °C
Humidity:	15% - 93% relative humidity (non-condensing)
Air pressure:	540 hPa – 1060 hPa

13.8 Stimulation parameters

- Symmetrical biphasic (first anodic) rectangular pulse
- Frequency 20 Hz
- Pulse duration 10 ms
- Maximum stimulation amplitude 950 µA
- Stimulation duration 30 minutes

13.9 Key performance feature

The OkuStim 2 (OK200008) and its variants must not emit an effective current above 10 mA (device maximum). The loss of the essential performance feature can lead to irreversible damage to the eyes. The key performance feature is continuously and automatically monitored and maintained by OkuStim 2.

13.10 Basic safety

OkuStim 2 does not output any direct current components > 80 mA (limit for DC is 80 mA). OkuStim 2 checks itself and does not need to be checked externally. An external inspection is not possible.

14 Disposal of old devices

Used OkuEI M and OkuEI counter electrodes can be disposed of as normal household waste. For further information, please contact Okuvision GmbH or your dealer.



14.1 Disposal of electrical and electronic devices

The crossed-out wheellie bin symbol indicates that you are legally obliged to dispose of these items separately from unsorted household waste. Disposal in the household waste bin or the yellow bin is prohibited.

14.2 Data protection

We would like to point out to all end users of electrical and electronic equipment that you are responsible for deleting any personal data on the equipment prior to disposal. Consult your doctor or dealer if necessary.

15 Warranty

For all components of the OkuStim 2 system, the legal warranties apply.

Restrictions of the warranty

The warranty is subject to the following exceptions and limitations:

- The warranty is limited to replacement in case of material or manufacturing faults. Okuvision GmbH is not obliged to replace devices whose malfunction or damage has been caused by misuse, accidents, alterations, incorrect use, negligence or unprofessional maintenance. In addition, Okuvision GmbH does not assume any liability for damages or malfunctions of OkuStim 2 systems, which have been caused through the utilization of products other than those manufactured by Okuvision GmbH.
- Okuvision GmbH reserves the right to replace devices in the event of a warranty claim with an equivalent successor model, which may have design changes.

Regardless of the legal warranty claims, Okuvision GmbH does not issue any other guarantees for this product. Liability for damages or consequential damages, even in the case where Okuvision GmbH was informed about the possibility of such damages, exists only within the framework of the legal regulations.

16 Accessories

Article number	Product description
OK200004	OkuEI® M Package
OK200009	OkuStim® 2 Nosepad Kit

The OkuStim 2 system is available in different versions. Ask your local dealer for the configuration you require.

17 Notes on radio technology

Frequency:	2445 MHz (±0.5 MHz)
Modulation:	GFSK
Performance (e.r.p.):	-16 dBm
Contains FCC ID:	R7T1101102

The enclosed device complies with Part 15 of the FCC regulations.

Operation is dependent on the following two conditions:



1. this device may not cause harmful interference and
2. this device must accept any interference received, including interference that may cause undesired operation.

18 Notes on electromagnetic compatibility

When operating the OkuStim 2 system, it is essential to comply with the EMC instructions and regulations. This device has been tested and meets the requirements for medical electrical equipment in accordance with CISPR 11, Group 1, Class B. The applicable limits are intended to provide reasonable protection against electromagnetic interference when the device is operated in a domestic environment or in doctors' surgeries in residential areas. Furthermore, the device can also be used in professional healthcare facilities, e.g. in clinics. This device generates and uses high-frequency energy and may also emit it; if not used in accordance with the operating instructions, it may cause harmful interference to radio communications.

Normal state and first fault state (EMC):

The OkuStim 2 system emits stimulation currents with a set current intensity. In the event of a fault that causes stimulation currents to deviate from the set value, the device can switch off the stimulation; the essential performance characteristic is always maintained.

Warning notice:	
	Use of the OkuStim 2 system directly adjacent to other devices or stacked with other devices should be avoided, as this could result in malfunction. If use in the prescribed manner is nevertheless necessary, this device and the other devices should be monitored to ensure that they are operating correctly.
Warning notice:	
	The use of other accessories and cables not listed in the accessories list or provided by the manufacturer of this device could result in increased electromagnetic emissions or reduced electromagnetic immunity of the system and lead to its malfunction.
Warning notice:	
	Portable RF communication devices (including accessories such as antenna cables or external antennas) must be kept at least 30 cm (12 inches) away from the OkuStim 2 system and all its components, including cables. Otherwise, the performance of the system could be impaired. See Table 18-1 and Table 18-2.

The system is intended for use in an electromagnetic environment with the following specifications. The purchaser or user of the system must ensure that it is used in such an electromagnetic environment.

Interference immunity test	IEC 60601 test level	Conformity level	EMC information
Electrostatic discharge (ESD) in accordance with IEC 61000-4-2	±8 kV contact discharge ±2, ±4, ±8 and ±15 kV air discharge	±8 kV contact discharge ±2, ±4, ±8 and ±15 kV air discharge	The floor should be made of wood, concrete or ceramic tiles. If the floor is made of synthetic material, the relative humidity must be at least 30%.
Conducted RF disturbances according to IEC 61000-4-6	3 V RMS 150 kHz – 80 MHz 6 V RMS 150 kHz – 80 MHz within ISM and amateur radio frequency bands 80% AM at 1 kHz	3 V RMS 150 kHz – 80 MHz 6 V RMS 150 kHz – 80 MHz within ISM and amateur radio frequency bands 80% AM at 1 kHz	Portable and mobile RF communications equipment should be used no closer than 30 cm (12 inches) to any part of the system, including cables.
Radiated RF disturbances according to IEC 61000-4-3	10 V/m 80 Hz - 2.7 GHz 80% AM at 1 kHz	10 V/m 80 Hz - 2.7 GHz 80% AM at 1 kHz	
Magnetic fields with energy frequencies IEC 61000-4-8	30 A/m 50 Hz or 60 Hz	30 A/m 50 Hz; 60 Hz	
Magnetic fields at close range IEC 6100-4-39	30 kHz, Modulation CW, 8 A/m 134.2 kHz, Pulse modulation 2.1 kHz, 2.1 kHz, 65 A/m 13.56 MHz, Pulse modulation 50 kHz, 7.5 A/m	30 kHz; Modulation CW; 8 A/m 134.2 kHz, Pulse modulation 2.1 kHz, 2.1 kHz, 65 A/m 13.56 MHz, Pulse modulation 50 kHz, 7.5 A/m	

Table 14.2-1: IEC 60601-1-2:2014, Electromagnetic immunity; ESD, conducted and radiated disturbances, magnetic fields

Test frequency [MHz]	Band [MHz]	Wireless service	Modulation	Distance [m]	Maximum power [W]	Interference immunity test level [V/m]
385	380 to 390	TETRA 400	Pulse modulation 18 Hz	0.3	1.8	27
450	430 to 470	GMRS 460, FRS 460	5 kHz Hub 1 kHz sine wave	0.3	2	28
710	704 to 787	LTE Band 13,17	Pulse modulation 217 Hz	0.3	0.2	9
745						
780						
810	800 to 960	GSM 800/900, TETRA 800, iDEN 820, CDMA 850, LTE Band 5	Pulse modulation 18 Hz	0.3	2	28
870						
930						
1720	1700 to 1990	GSM 1800; CDMA 1900; GSM 1900; DECT; LTE Band 1.3, 4.25; UMTS	Pulse modulation 217 Hz	0.3	2	28
1845						
1970						
2450	2400 to 2570	Bluetooth, WLAN, 802.11 b/g/n, RFID 2450, LTE Band 7	Pulse modulation 217 Hz	0.3	2	28
5240	5100 to 5800	WLAN 802.11 a/n	Pulse modulation 217 Hz	0.3	0.2	9
5500						
5785						

Table 14.2-2: IEC 60601-1-2:2014, Immunity to high-frequency electromagnetic fields in the immediate vicinity of wireless communication devices

Annex 1: For healthcare professionals and dealers only - Handling and application

A.1 Adjusting OkuStim 2

OkuStim 2 should only be adjusted to the patient's face shape by trained healthcare professionals and dealers (see Chapter A.3). The electrode threads must lie on the surface of the eye (conjunctiva) below the pupil (see Fig. A3-1). To do this, the pull-fix knobs of OkuStim 2 are opened to allow the magnetic electrode holders and the nose bridge to be moved (see Fig. 1.1-1).

The magnetic electrode holders must first be set to zero (scaled to 0) to prevent the tips from accidentally touching the patient when swivelling.

OkuStim 2 is placed on the patient's head like a pair of glasses with their eyes closed. The electrode holders must be in the open position (position 2).

The size of the nose pad required by the patient is now determined, see chapter A.2.

All adjustments to OkuStim 2 are carried out in the swivelled-in state (position 0) (see Fig. 1.1-3). OkuStim 2 must be placed on the nose so that the system touches the forehead. The height of the nose pad can be adjusted so that OkuStim 2 lies as close as possible to the forehead.

Due to different anatomies, OkuStim 2 may slip off the nose. In such cases, a headband can be used to hold OkuStim 2 in position. This headband should then be used for every stimulation session.

The electrode holders can now be adapted to the patient's anatomy.

The eyes should be closed during the fitting. Patients are encouraged to follow the instructions of healthcare professionals.

The magnetic electrode holders must be adjusted so that the inner ones are positioned against the inner corner of the eye. To do this, the magnetic electrode holders are carefully moved towards the eye.

There are 11 adjustment options, more detailed explanations can be found in Table A.1- 1:

- 1 Nose pad height (N)
- 2 Horizontal/transverse adjustment options for the electrode holders (right and left respectively) (left eye - right eye)
- 4 adjustment options (nasal and temporal) towards the eye (2 on the right and 2 on the left)
- 4 height adjustment options (nasal and temporal) (2 on the right and 2 on the left)

A scale is indicated on the individual adjustment options. Every fifth unit is marked by a circumferential ring. Healthcare professionals use this scale to record patient-specific settings and can quickly adjust them again if necessary.

The electrode holder is correctly adapted to the patient when the OkuEI M thread lies below the pupil, above the lower eyelid on the surface of the eye (conjunctiva), without applying pressure, and is at least 1 cm long.

After the adjustment, all pull-fix elements must be closed so that the settings no longer change.

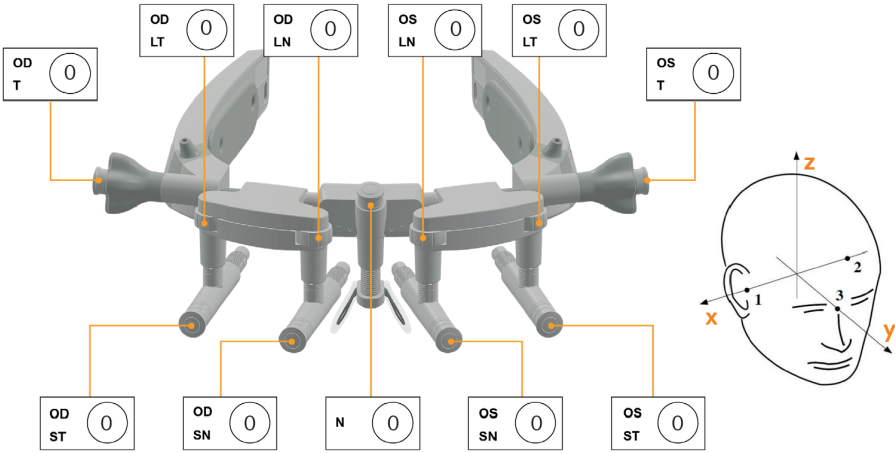

Fig. A.1-2: OkuStim 2 fitting

Adjustment options/coordinates	Axis	Right eye	Left eye	Description
Horizontal/transversal (ODT; OST)	x	ODT	OST	Transverse (lateral) adjustment of the entire electrode holder
Vertical/longitudinal nasal (OD LN; OS LN)	z	ODLN	OSLN	Height adjustment of the nasal magnetic electrode holders
Vertical/longitudinal temporal (OD LT; OS LT)	z	ODLT	OSLT	Height adjustment of the temporal magnetic electrode holders
Sagittal nasal (OD SN; OS SN)	y	ODSN	OSSN	Depth adjustment of the nasal magnetic electrode holders
Sagittal temporal (OD ST; OS ST)	y	ODST	OSSN	Depth adjustment of the temporal magnetic electrode holders
Nose (N)	z	N		Height adjustment of the nose pad
Nose pad sizes		S, M, L		-

Table A.1-1: OkuStim 2 adjustment options

A.2 The OkuStim 2 nose bridge exchange or replacement

The OkuStim 2 Nose Pad Kit OK200009 is available for replacing the nose bridge.

The OkuStim 2 Nose Pad Kit consists of

- **2x nose pads S** (on the product label OK000135 OkuStim 2 Nose pad S)
- **2x nose pads L** (on the product label OK000137 OkuStim 2 Nose pad L)
- **1x nose pad screws** (on the product label OK000173 OkuStim 2 Nose pad screws)
- **1x screwdriver** (on the product label OK000132 OkuStim 2 TX3)

Proceed as follows to replace the nose bridge:

- Place OkuStim 2 upside down on the table. The screws are located on the side facing the head.
- Loosen the two screws of the nose bridge with the OkuStim 2 TX3 screwdriver.
- Remove the screws and the nose bridge from OkuStim 2.
- Remove the two screws from the nose bridge and put them to one side.
- Remove the nose bridge of the desired size from the OkuStim 2 Nose Pad Kit.
- Attach the new nose bridge to OkuStim 2 using the screws.
- If you lose one of the screws, you will find a replacement screw in the OkuStim 2 Nose Pad Kit.
- Tighten both screws carefully. It is important that the screws are not overtightened to avoid damaging the nose bridge mount.

A.3 Patient workflow

- Before placing OkuStim 2 on the patient's head, the swivel mechanism must be moved to position 2 (fully open) using the rotary handle.
- The OkuStim 2 pull-fix knobs (1, 2, 3, 6; for both sides of OkuStim 2) must be open (see chapter 1).
- The magnetic electrode holders (z-axis) must now first be retracted (scaled to 0) so that the tips of the magnetic electrode holders do not accidentally touch the patient's face when the electrode holders are swivelled in.
- The patient should sit comfortably and keep their head reclined for the duration of the adjustment/fitting.
- The patient must keep their eyes closed and be informed when their eyes can be opened.
- The eyes should be adjusted one after the other.

Select and adjust nose pads

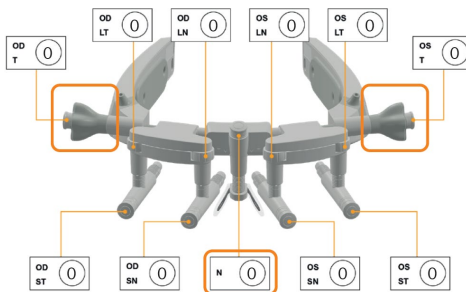

1. Place OkuStim 2 on the patient.
2. Check that the nose pad is the correct size. Replace it if necessary (see chapter A.3). The nose pad should lie as close as possible to the nose.
3. Raise/lower the nose pad using the rotary knob (N) so that OkuStim 2 lies as flat as possible on the forehead, above the eyebrows.

Table A.3-1: Select and adjust nose pads

Adjust electrode position

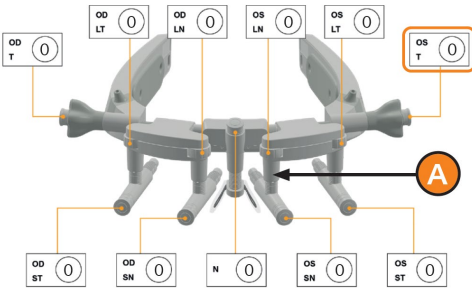

Horizontal adjustment:

1. Use the rotary handles to swivel the electrode holders into position 0.
2. Align the nasal vertical element (A) to the inner corner of the eye using the rotary knob (OST).

(OST enables the electrode holder to be moved along the x-axis / transversely on the left eye (OS))

Adjustment of the height:

3. Raise or lower the nasal magnetic electrode holder (B) using the rotary knob (OSLN) until its tip is aligned with the inner corner of the eye.
4. The rotary knob (OSLT) allows you to lower/raise the temporary magnetic electrode mount (C) vertically.
5. The tips of the two magnetic electrode holders (B-C) must be aligned so that the thread has at least 1 cm of contact with the surface of the eye (conjunctiva) (see image).

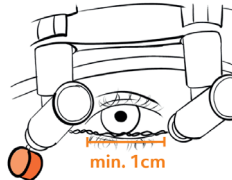
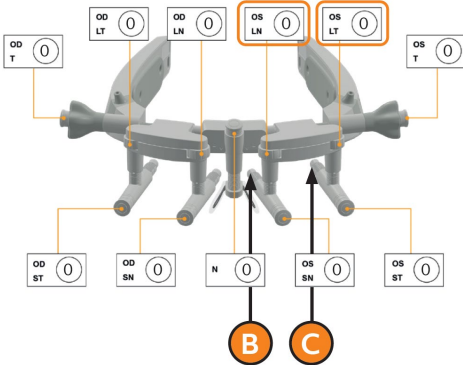

(OSLN - OSLT allow the magnetic electrode holders to be moved along the z-axis / longitudinally)

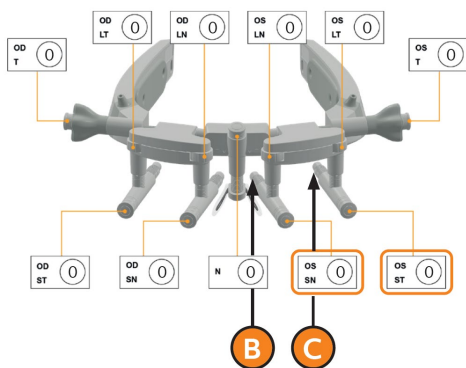

Adjustment of the distance to the corner of the eye:

6. Bring the nasal magnetic electrode holder (B) closer to the face using the rotary knob (OSSN) so that the tip of the magnetic electrode holder touches the inner corner of the eye.
7. Use the rotary knob (OSST) to move the temporal magnetic electrode holder (C) closer to the face until it is approximately 1–2 mm from the skin.
8. The tips of the two magnetic electrode holders (B-C) must be aligned so that the thread is in contact with the surface of the eye (conjunctiva) for at least 1 cm. (OSSN – OSST) enable the magnetic electrode holders to be moved along the y-axis (sagittal).

Table A.3-2: Adjust electrode position

After the first eye has been adjusted, continue with the other eye. Repeat steps 1 to 7 in the same order. Then close the Pull-Fix knobs again.

Using the OkuEI M

- Move both electrode holders to position 2 and remove OkuStim 2 from the patient.
- Take two OkuEI M blister packs from the OkuEI M package.
- Open the blister pack completely. The blister pack also serves as a guide for attaching the electrode to the electrode holder without touching it (see Table 5- 1: Insert the OkuEI M electrodes).
- Approach the electrode holder with the blister pack. The orange seal must face outwards. The electrode is magnetically attracted to the electrode holder and aligned.
- Now attach the second electrode.
- Put OkuStim 2 back on the patient's head.
- The patient's head should be reclined and the eyes must be open.
- Pull down the lower eyelid and swivel in the first electrode holder using the rotary handles (move to position 0). Check the position of the OkuEI M thread.
- The OkuEI M threads should have at least 1 cm contact with the eyes.
- If the electrodes are not perfectly positioned, you can adjust the position of the electrode thread using the rotary knobs while the electrode is resting on the eye (fine adjustment).

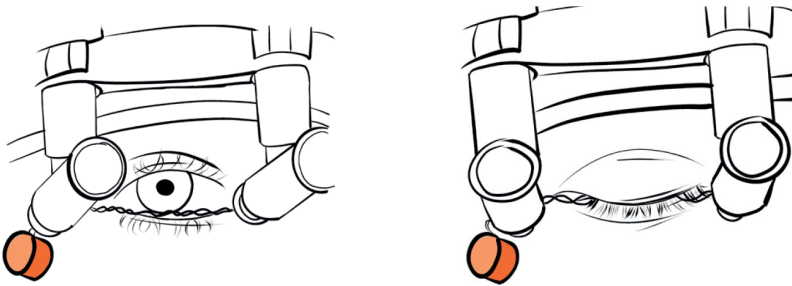

Fig. A.3-1: Using the OkuEI M

Attach the OkuEI counter electrodes

1. Swivel the electrode holders back to position 2 and remove OkuStim 2 from the patient. Place it down carefully and ensure that the electrodes do not touch anything.
2. Thoroughly clean the forehead between the eyebrows and hairline, where you will attach the counter electrodes on the right and left, with alcohol pads. Wait until the skin is dry.
3. Open the packaging of the counter electrode. Try not to tear the packaging so that it can be resealed.
4. Remove a counter electrode from the backing foil and stick it to the forehead. Then attach the second counter electrode.
5. Ensure that the counter electrodes are not covered by OkuStim 2.
6. Now lubricate the patient's eyes with eye drops. The eyes should always be well lubricated during stimulation.
7. Start the OkuStim Pulse software on your PC (see OkuStim Pulse instructions for use). Switch on the OkuStim 2 and set it to pairing mode.
8. Put OkuStim 2 back on the patient's head.
9. Connect the OkuStim 2 counter electrode cables to the OkuEI counter electrodes.
If the position of OkuStim 2 makes it difficult to connect the snap connectors of the counter electrode cables, OkuStim 2 can be moved slightly forward on the nose to provide more space.. After connecting the OkuEI counter electrodes, OkuStim 2 can then be repositioned against the forehead.
10. The patient must have their head reclined and their eyes open.
11. Pull down the lower eyelid and turn the electrode holders with the rotary handles to position 0 (closed).
12. The OkuEI M threads should have at least 1 cm contact with the eyes.
13. The patient can now close their eyes and the stimulation can begin.
14. Now seal the counter electrode packaging well so that the remaining counter electrode(s) do not dry out.

A.4 Error handling

Application problems during stimulation

If the error cannot be rectified using the solutions listed in Chapter 12, Table 12-1, the steps described below must be carried out. These steps may only be carried out by trained personnel.



Errors during stimulation	
Error message/problem	Solution
 <p>OR</p>  <ul style="list-style-type: none"> LED at the bottom flashes red on the side of the error A tone sequence can be heard on the side of the error: <u>2 double tones high – low (with echo)</u> 	<ol style="list-style-type: none"> 1. Pause the stimulation. 2. <u>After each of the following steps, check whether this resolves the error by resuming the stimulation (pressing the start/pause button). Pause again if necessary. Avoid turning the dials to the maximum or minimum setting.</u> <ul style="list-style-type: none"> • Open the pull-fix lock for horizontal adjustment of the OkuEI M position on the nose side (closer to/further from the corner of the eye, pos. 1 in figure). Now turn the pull-fix knob 360° forwards and 360° backwards. To return to the original setting. Use the scale for orientation. Close the pull-fix lock again. • Turn the rotary knob for the height adjustment on the side of the nose (pos. 2) 360° out and 360° back. To return to the original setting. Use the scale for orientation. • Open the pull-fix lock for lateral adjustment of the OkuEI M position (left/right movement). Now turn the pull-fix knob (pos. 3) 360° outwards and 360° backwards. To return to the original setting. Use the scale for orientation. Close the pull-fix lock again. <p>ATTENTION: If turning the pull-fix knobs does not result in an adjustment of the electrode holders, contact your dealer or Okuvision GmbH.</p> 

Table A.4-1: Errors during stimulation

For healthcare professionals only – Application problems during therapy parameter determination with the OkuStim Pulse software

Application problems during therapy parameter determination with the OkuStim Pulse software

Error message/problem	Solution
OkuStim 2 cannot be connected wirelessly to the OkuStim Pulse (OSP) software	<ul style="list-style-type: none"> • Check whether the wireless module (OkuStim® Wireless Dongle) has been recognised by your PC: In the OkuStim Pulse Software (OSP), successful detection is indicated by a green check mark in step 1 "Connect wireless dongle". • If the wireless module is not recognised: <ol style="list-style-type: none"> 1. Close OSP. 2. Remove the wireless module and reinsert it. Under normal conditions, the operating system should confirm successful detection with a beep. 3. Start the OSP again. 4. Try to establish a connection again. • Measures with OkuStim 2: <ol style="list-style-type: none"> 1. Switch off OkuStim 2. 2. Switch it on again by pressing and holding the on/off button for at least 6 seconds. OkuStim 2 then indicates pairing mode by the blue flashing LED on the side. 3. Try to establish a connection to OkuStim 2 with OSP again. • If the problem persists, please also refer to the suggested solutions in the following section.
Connection failure between OkuStim 2 and the OkuStim Pulse	<ol style="list-style-type: none"> 1. Place OkuStim 2 and the wireless dongle as close together as possible on the computer. The wireless module in OkuStim 2 is located on the right-hand side. 2. Restart the OkuStim Pulse software. <ul style="list-style-type: none"> • If the problem persists, try using a different room. <p>Alternatively, if the problem persists and occurs during tolerance threshold determination:</p> <ol style="list-style-type: none"> 1. Connect OkuStim 2 to the computer using the USB cable supplied. 2. Set a therapy value and transmit it to OkuStim 2 via cable. 3. Remove the cable and test the value on the patient for at least 30 seconds, as in normal stimulation mode. Please note that the set value is only reached after 30 seconds. 4. Repeat steps 1 to 3 until you have determined the desired therapy value.

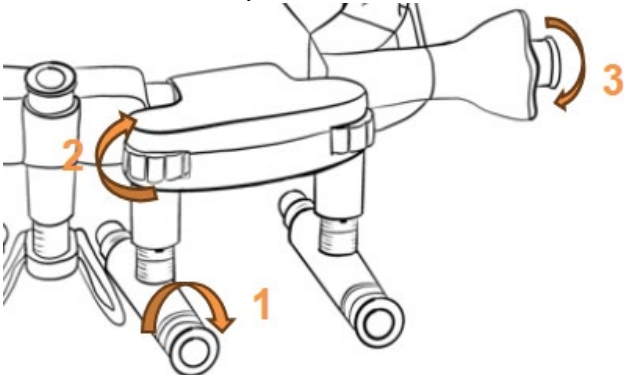
System error when transferring log files between OkuStim 2 and OkuStim Pulse

1. Allow the transfer process to run completely (until all visible loading bars have reached the end).
 2. Disconnect OkuStim Pulse from OkuStim 2.
 3. Restart the OkuStim Pulse software.
 4. Re-establish the connection between OkuStim Pulse and OkuStim 2.
- If the error still occurs, please contact Okuvision GmbH.

When the start/pause button is pressed, the 4 LEDs at the front light up red for 2 seconds.



2 seconds

- All 4 LEDs at the front light up red for 2 seconds.
- Tone: 1 low double tone (with echo)

It is not permitted to start therapy by pressing the start/pause button when the cable is plugged in or the wireless connection is active. If you want to start stimulation without a connection to a PC:

1. Disconnect the wireless or cable connection to OkuStim 2.
2. Switch on OkuStim 2 and restart the therapy by pressing the start/pause button.

Table A.4-2: Application problems during therapy parameter determination with the OkuStim Pulse software

